

# Rinnai®

## Outdoor Tankless Water Heater Installation and Operation Manual

FOR OUTDOOR APPLICATIONS ONLY

V53De..... REU-AM1620WD-US



Full-length French and Spanish versions  
available online at [rinnai.us](http://rinnai.us)

This entire manual must be left for the consumer.  
The consumer must read and refer to this manual for  
proper operation and to maintain the water heater.

Place  
Model/Serial #  
Label Here

Located in Manual Bag



Low Lead Content  
NSF/ANSI 372



ANSI Z21.10.3 • CSA 4.3

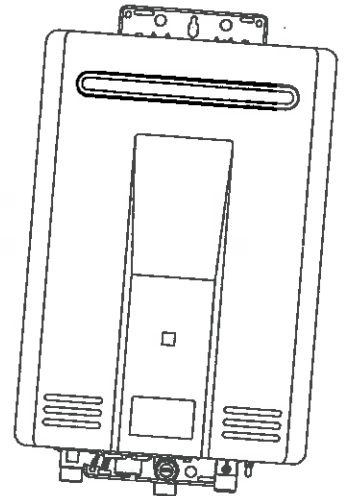

### READ ALL OF THE INSTRUCTIONS THOROUGHLY BEFORE INSTALLING OR OPERATING THIS WATER HEATER.

This manual provides information on the installation, operation, and maintenance of the water heater. For proper operation and safety, it is important to follow the instructions and adhere to the safety precautions. A licensed professional must install the water heater according to the exact instructions on pages 4-20. The consumer must read the entire manual to properly operate the water heater and to have regular maintenance performed.

#### **WARNING**

If the information in these instructions is not followed exactly, a fire or explosion may result causing property damage, personal injury or death.

- Do not store or use gasoline or other flammable vapors and liquids in the vicinity of this or any other appliance.
- WHAT TO DO IF YOU SMELL GAS:
  - Do not try to light any appliance.
  - Do not touch any electrical switch; do not use any phone in your building.
  - Immediately call your gas supplier from a neighbor's phone. Follow the gas supplier's instructions.
  - If you cannot reach your gas supplier, call the fire department.
- Installation and service must be performed by a licensed professional.

#### **WARNING**

Assurez-vous de bien suivre les instructions données dans cette notice pour réduire au minimum le risque d'incendie ou d'explosion ou pour éviter tout dommage matériel, toute blessure ou la mort.

- Ne pas entreposer ni utiliser d'essence ou ni d'autres vapeurs ou liquides inflammables à proximité de cet appareil ou de tout autre appareil.
- QUE FAIRE SI VOUS SENTEZ UNE ODEUR DE GAZ :
  - Ne pas tenter d'allumer d'appareil.
  - Ne touchez à aucun interrupteur ; ne pas vous servir des téléphones se trouvant dans le bâtiment.
  - Appelez immédiatement votre fournisseur de gaz depuis un voisin. Suivez les instructions du fournisseur.
  - Si vous ne pouvez rejoindre le fournisseur, appelez le service des incendies.
- L'installation et l'entretien doivent être assurés par un installateur ou un service d'entretien qualifié ou par le fournisseur de gaz.

## Table of Contents

Table of Contents.....	2	Final Checklist.....	16
Safety Behaviors and Practices for the Consumer and Installer.....	3	Technical Data .....	17
<b>Installation Instructions (for the licensed professional) .....</b>	<b>4</b>	Specifications .....	17
Prepare for Installation.....	5	Dimensions.....	18
Determine Installation Location.....	5	Pressure Drop and Water Flow Curves.....	19
Water Quality .....	5	Ladder Diagram.....	20
Checklist to Determine Installation Location ....	8	<b>Operation Instructions .....</b>	<b>21</b>
Freeze Protection .....	8	Consumer Operation Guidelines for the Safe Operation of your Water Heater.....	22
Mount to Wall .....	8	How to Use the Temperature Controller .....	23
Remove the Front Panel.....	9	How to Set the Temperature .....	24
Installation of Plumbing.....	9	Diagnostic Codes .....	27
Checklist for Plumbing.....	11	Required Maintenance.....	29
Installation of Gas Supply .....	11	Freeze Protection and Winterizing .....	30
Connect Electricity.....	13	Flushing the Heat Exchanger .....	31
Adjust for High Altitude.....	13	Manual Draining of the Water Heater .....	32
Checklist for Gas and Electricity .....	13	Consumer Warranty .....	33
Installation of Temperature Controller .....	14		
Mounting the Controller.....	15		

NOTICE: Rinnai sometimes shares customer contact information with businesses that we believe provide products or services that may be useful to you. By providing this information, you agree that we can share your contact information for this purpose. If you prefer not to have your information shared with these businesses, please contact customer service and ask not to have your information shared. We will however, continue to contact you with information relevant to the product(s) you registered and/or you account with us.

If you have any questions or feel that the manual is incomplete contact Rinnai at 1-800-621-9419.

## Important Safety Information

### Safety Definitions



This is the safety alert symbol. This symbol alerts you to potential hazards that can kill or hurt you and others.



Indicates an imminently hazardous situation which, if not avoided, will result in death or serious injury.



Indicates a potentially hazardous situation which, if not avoided, could result in death or serious injury.



Indicates a potentially hazardous situation which, if not avoided, could result in minor or moderate injury. It may also be used to alert against unsafe practices.

## Safety Behaviors and Practices for the Consumer and Installer

### **⚠ WARNING / AVERTISSEMENT**

- Before operating, smell all around the appliance area for gas. Be sure to smell next to the floor because some gas is heavier than air and will settle on the floor.
- Keep the area around the appliance clear and free from combustible materials, gasoline, and other flammable vapors and liquids.
- Combustible construction refers to adjacent walls and ceiling and should not be confused with combustible or flammable products and materials. Combustible and/or flammable products and materials should never be stored in the vicinity of this or any gas appliance.
- Always check the water temperature before entering a shower or bath.
- To protect yourself from harm, before performing maintenance:
  - ◇ Turn off the electrical power supply by unplugging the power cord or by turning off the electricity at the circuit breaker. (The temperature controller does not control the electrical power).
  - ◇ Turn off the gas at the manual gas valve, usually located immediately below the water heater.
  - ◇ Turn off the incoming water supply. This can be done at the isolation valve immediately below the water heater or by turning off the water supply to the building.
- Use only your hand to push in or turn the gas control knob. Never use tools. If the knob will not push in or turn by hand, do not try to repair it; call a licensed professional. Force or attempted repair may result in a fire or explosion.
- Do not use this appliance if any part has been under water. Immediately call a licensed professional to inspect the appliance and to replace any part of the control system and any gas control which has been under water.  
*(N'utilisez pas cet appareil s'il a été plongé dans l'eau, même partiellement. Faites inspecter l'appareil par un technicien qualifié et remplacez toute partie du système de contrôle et toute commande qui ont été plongés dans l'eau).*
- Do not use substitute materials. Use only parts certified with the appliance.
- Should overheating occur or the gas supply fail to shut off, turn off the manual gas control valve to the appliance.  
*(En cas de surchauffe ou si l'alimentation en gaz ne s'arrête pas, fermez manuellement le robinet d'arrêt de l'admission de gaz).*
- Do not adjust the Dip switch unless specifically instructed to do so.
- Do not use an extension cord or an adapter plug with this appliance.
- Any alteration to the appliance or its controls can be dangerous and will void the warranty.

### **⚠ CAUTION**

- **BURN HAZARD.** Hot exhaust and exhaust outlet may cause serious burns. Keep away from water heater unit. Keep small children and animals away from unit.
- Hot water outlet pipes leaving the unit can be hot to touch. In residential applications, insulation must be used for hot water pipes 36" or less (height) from the floors due to burn risk to children.

### **⚠ WARNING / AVERTISSEMENT**

California law requires the following Proposition 65 warning to be provided:

This product can expose you to chemicals including lead, lead compounds and carbon bisulfide which are known to the State of California to cause cancer, birth defects or other reproductive harm. For more information, visit [www.P65Warnings.ca.gov](http://www.P65Warnings.ca.gov).

# Installation Instructions

## Installer Qualifications

A licensed professional must install the appliance, inspect it, and leak test it before use. The warranty will be voided due to improper installation.

The installer should have skills such as:

- gas sizing
- connecting gas lines, water lines, valves, electricity,
- knowledge of applicable national, state, and local codes.

If you lack these skills contact a licensed professional.

## Type of installation

- For installation in residential applications.
- Certified for installation in manufactured (mobile) homes.

## Installation Steps

Prepare for Installation .....	5
Determine Installation Location.....	5
Checklist to Determine Installation Location .....	8
Mount to Wall .....	8
Remove the Front Panel .....	9
Installation of Plumbing .....	9
Checklist for Plumbing .....	11
Installation of Gas Supply.....	11
Connect Electricity .....	13
Adjust for High Altitude .....	13
Checklist for Gas and Electricity.....	13
Installation of Temperature Controller.....	14
Mounting the Controller .....	15
Final Checklist.....	16

## General Instructions

### DO NOT

- Do not install the V53De indoors.
- Do not install the appliance in an area where water leakage of the unit or connections will result in damage to the area adjacent to the appliance or to lower floors of the structure. When such locations cannot be avoided, it is recommended that a suitable drain pan, adequately drained, be installed under the appliance. The pan must not restrict combustion air flow.

- Do not obstruct the flow of combustion and ventilation air. Combustion air shall not be supplied from occupied spaces.
- Do not use this appliance in an application such as a pool or spa heater that uses chemically treated water. (This appliance is suitable for filling large or whirlpool spa tubs with potable water.)
- Do not use substitute parts that are not authorized for this appliance.

### MUST DO

- The installation must conform with local codes or, in the absence of local codes, with the *National Fuel Gas Code, ANSI Z223.1/NFPA 54*, or the *Natural Gas and Propane Installation Code, CSA B149.1*. If installed in a manufactured home, the installation must conform with the *Manufactured Home Construction and Safety Standard, Title 24 CFR, Part 3280* and/or *CAN/SCA Z240 MH Series, Mobile Homes*.
- The appliance, when installed, must be electrically grounded in accordance with local codes or, in the absence of local codes, with the *National Electrical Code, ANSI/NFPA 70*, or the *Canadian Electrical Code, CSA C22.1*.
- The appliance and its appliance main gas valve must be disconnected from the gas supply piping system during any pressure testing of that system at test pressures in excess of 1/2 psi (3.5 kPa) (13.84 in W.C.).
- The appliance must be isolated from the gas supply piping system by closing its individual manual shutoff valve during any pressure testing of the gas supply piping system at test pressures equal to or less than 1/2 psi (3.5 kPa) (13.84 in W.C.).
- You must follow the installation instructions and those in *Care and Maintenance* for adequate combustion air intake and exhaust.

### INFORMATION

- If a water heater is installed in a closed water supply system, such as one having a backflow preventer in the cold water supply line, means shall be provided to control thermal expansion. Contact the water supplier or local plumbing inspector on how to control thermal expansion.

- Should overheating occur or the gas supply fail to shut off, turn off the manual gas control valve to the appliance.
- Keep the air intake location free of chemicals such as chlorine or bleach that produce fumes. These fumes can damage components and reduce the life of your appliance.

## Prepare for installation

### Parts included

- Tankless water heater

### Tools needed

- Pipe wrenches (2)
- Adjustable pliers
- Screwdrivers (2)
- Wire cutters
- Gloves
- Safety glasses
- Level

### Tools that might be needed

- Hammer drill with concrete bits
- Saw
- Threading machine with heads and oiler
- Core drill with diamond head
- Torch set
- Copper tubing cutter
- Steel pipe cutter

### Materials needed

- Soap solution
- Pressure relief valve
- Teflon tape (recommended) or pipe compound

### Materials that may be needed

- Heat tape
- Pipe insulation
- Electrical wire and conduit per local code
- Concrete wall anchors
- Optional pipe cover
- Optional temperature controller
- 5/8" ID PVC flexible tubing
- 2 conductor 22 AWG wire for controller
- Single gang electrical box
- Wire nuts
- Unions, drain valves, isolation valves

## Determine Installation Location

You must ensure that clearances will be met. Consider the installation environment, water quality, and need for freeze protection. Requirements for the gas line, water lines, electrical connection, and

condensate disposal can be found in their respective installation sections of this manual.

## Water Quality

Consideration of care for your water heater should include evaluation of water quality.

The water must be potable, free of corrosive chemicals, sand, dirt, or other contaminants. It is up to the installer to ensure the water does not contain corrosive chemicals, or elements that can affect or damage the heat exchanger. Water that contains chemicals exceeding the levels below affect and damage the heat exchanger. Replacement of the heat exchanger due to water quality damage is not covered by the warranty.

	Maximum Level
Total Hardness	Up to 200 mg / L
Aluminum *	Up to 0.2 mg / L
Chlorides *	Up to 250 mg / L
Copper *	Up to 1.0 mg / L
Dissolved Carbon Dioxide (CO <sub>2</sub> )	Up to 15.0 mg / L or PPM
Iron *	Up to 0.3 mg / L
Manganese *	Up to 0.05 mg / L
pH *	6.5 to 8.5
TDS (Total Dissolved Solids) *	Up to 500 mg / L
Zinc *	Up to 5 mg / L

\* Source: Part 143 National Secondary Drinking Water Regulations

If you install this water heater in an area that is known to have hard water or that causes scale build-up the water must be treated and/or the heat exchanger flushed regularly.

When scale build-up in the heat exchanger begins to affect the performance of the water heater, a diagnostic code "LC#" will display. Flush the heat exchanger to prevent damage to it. Scale build up is caused by hard water set at a high temperature.

Rinnai offers Southeastern Filtration's "ScaleCutter Water Conditioning System" that offers superior lime scale prevention and corrosion control by feeding a blend of control compounds into the cold water supply.

Part Number	Description
103000038	Southeastern Filtration ScaleCutter System 3/4" Feed
103000039	ScaleCutter Refill

# Exhaust Outlet Clearances

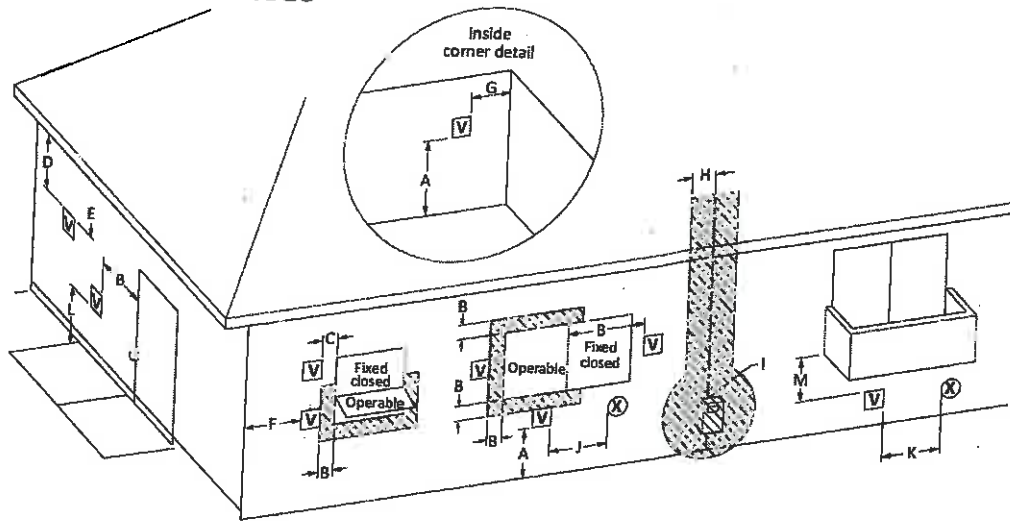

**Legend:**

- = Vent terminal
- = Air supply inlet
- = Area where terminal is not permitted

Ref	Description	Canadian Installations (CSA B149.1)	US Installations (ANSI Z223.1 / NFPA 54)
A	Clearance above grade, veranda, porch, deck, or balcony	12 inches (30 cm)	12 inches (30 cm)
B	Clearance to window or door that may be opened	6 in (15 cm) for appliances ≤ 10,000 Btuh (3 kW), 12 in (30 cm) for appliances > 10,000 Btuh (3 kW) and ≤ 100,000 Btuh (30 kW), 36 in (91 cm) for appliances >100,000 Btuh (30 kW)	4 ft (1.2 m) below or to side of opening 1 ft (300 mm) above opening
C	Clearance to permanently closed window	*	*
D	Vertical clearance to ventilated soffit, located above the terminal within a horizontal distance of 2 feet (61 cm) from the center line of the terminal	*	*
E	Clearance to unventilated soffit	*	*
F	Clearance to outside corner	*	*
G	Clearance to inside corner	*	*
H	Clearance to each side of center line extended above meter/regulator assembly	*	*
I	Clearance to service regulator vent outlet	Above a regulator within 3 ft (91 cm) horizontally of the vertical center line of the regulator vent outlet to a maximum vertical distance of 15 ft (4.5 m)	*
J	Clearance to non-mechanical air supply inlet to building or the combustion air inlet to any other appliance	6 in (15 cm) for appliances ≤ 10,000 Btuh (3 kW), 12 in (30 cm) for appliances > 10,000 Btuh (3 kW) and ≤ 100,000 Btuh (30 kW), 36 in (91 cm) for appliances >100,000 Btuh (30 kW)	4 ft (1.2 m) below or to side of opening 1 ft (300 mm) above opening
K	Clearance to a mechanical air supply inlet	6 feet (1.83 m)	3 feet (91 cm) above if within 10 feet (m) horizontally
L	Clearance above paved sidewalk or paved driveway located on public property	7 feet (2.13 m) ⊕	7 feet (2.13 m)
M	Clearance under veranda, porch, deck, or balcony	12 inches (30 cm) ⊕	*

[1] A vent shall not terminate directly above a sidewalk or paved driveway that is located between two single family dwellings and serves both dwellings.  
 [2] Permitted only if veranda, porch, deck, or balcony is fully open on a minimum of two sides beneath the floor.

• For clearances not specified in ANSI Z223.1/NFPA 54 or CSA B149.1, one of the following shall be indicated:  
 A. a minimum clearance value determined by testing in accordance with Clause 5.21, Draft hoods; or  
 B. a reference to the following footnote: "Clearance in accordance with local installation codes and the requirements of the gas supplier."

## Additional clearances

Local codes supersede these clearances.

- Avoid termination locations near a dryer vent.
- Avoid termination locations near commercial cooking exhaust.

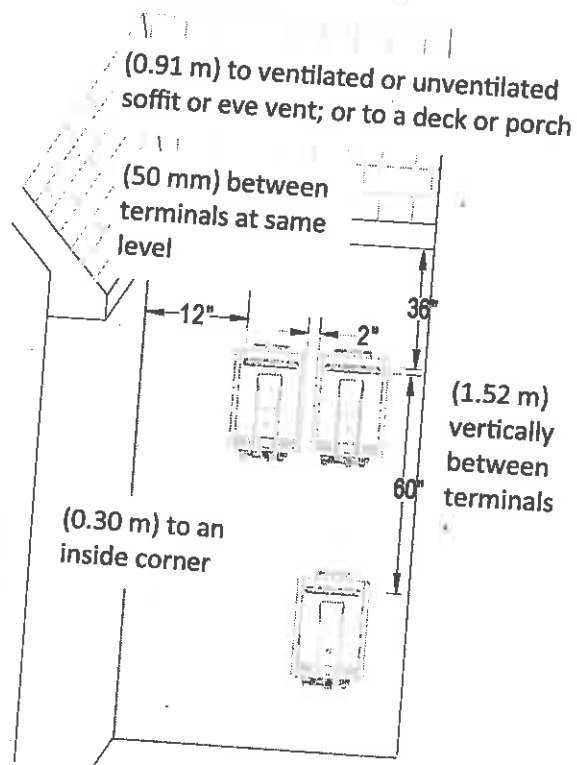

## Unit clearances

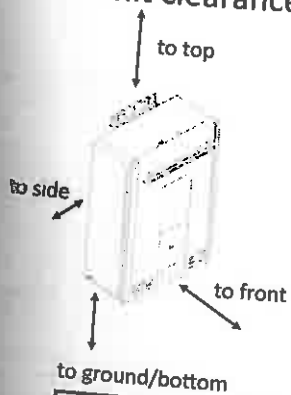

The clearance for servicing is 24 inches in front of the water heater.

	to Combustibles inches (mm)	to Non-Combustibles inches (mm)
Top of Heater	12 (305)	2 (51)
Back of Heater	0 (zero)	0 (zero)
Front (Panel)	24 (610)	0 (zero)
Front (Exhaust)	24 (610)	24 (610)
Sides of Heater	6 (152)	1/8 (3.2)
Ground/Bottom	12 (305)	2 (51)

## Environment

Air surrounding the water heater is used for combustion and must be free of any compounds that cause corrosion of internal components. These include corrosive compounds that are found in aerosol sprays, detergents, bleaches, cleaning solvents, oil based paints/ varnishes, and refrigerants. The air in beauty shops, dry cleaning stores, photo processing labs, and storage areas for pool supplies often contains these compounds. Therefore it is recommended that outdoor models be used for these locations where possible.

The water heater should not be installed in any areas where the air may contain these corrosive compounds. If it is necessary for a water heater to be located in areas which may contain corrosive compounds, the following instructions are strongly recommended.

### IMPORTANT CONSIDERATIONS:

- Install the water heater as far away as possible from exhaust vent hoods.
- Install as far away as possible from air inlet vents. Corrosive fumes may be released through these vents when air is not being brought in through them.
- Chemicals that are corrosive in nature should not be stored or used near the water heater.

Damage and repair due to corrosive compounds in the air is not covered by warranty.

## Checklist to Determine Installation Location

- The water heater is not exposed to corrosive compounds in the air.
- The water heater location complies with the clearances.
- The planned exhaust outlet/air intake location meets the clearances.
- The water supply does not contain chemicals or exceed total hardness that will damage the heat exchanger.
- A 120 VAC, 60 Hz source is available.
- The installation must conform with local codes or, in the absence of local codes, with the *National Fuel Gas Code, ANSI Z223.1/NFPA 54*, or the *Natural Gas and Propane Installation Code, CSA B149.1*. If installed in a manufactured home, the installation must conform with the *Manufactured Home Construction and Safety Standard, Title 24 CFR, Part 3280* and/or *CAN/SCA Z240 MH Series, Mobile Homes*.
- Leave the entire manual taped to the temperature controller (if installed), or give the entire manual directly to the consumer.

## Freeze Protection

Make sure that in case of freezing weather that the water heater and its water lines are protected to prevent freezing. Damage due to freezing is not covered by the warranty.

Loss of freeze protection may result in water damage from a burst heat exchanger or water lines.

With electrical power supplied, the water heater will not freeze when the outside air temperature is as cold as  $-4^{\circ}\text{F}$  ( $-20^{\circ}\text{C}$ ) for outdoor models, when protected from direct wind exposure. Because of the "wind-chill" effect, any wind or circulation of the air on the unit will reduce its ability to freeze protect.

The unit may be drained manually. However, it is highly recommended that:

- drain down solenoid valves are installed that will automatically drain the unit if power is lost. These are available in a kit, 104000059.

In addition, the solenoid valves should be connected electrically to a surge protector with terminals. This allows the solenoid valves to operate if the water heater is disabled due to a diagnostic code.

The freeze protection features will not prevent the external piping from freezing. It is recommended that hot and cold water pipes are insulated. Pipe cover enclosures may be packed with insulation for added freeze protection.

In the event of a power failure at temperatures below freezing the water heater should be drained of all water to prevent freezing damage. In addition, drain the condensate trap and drain line.

## Mount to Wall

1. Identify the installation location and confirm that the installation will meet all required clearances.
2. Securely attach the water heater to the wall using any of the holes in the wall installation brackets which are at the top and bottom of the water heater. Ensure that the attachment strength is sufficient to support the weight. Refer to the weight of the water heater in the Specifications section.

Use a leveling tool to ensure that the water heater is level. Proper operation requires that the water heater be level.

**NOTE:** The water heater should be installed in an upright position. Do not install upside down or on its side.



## Remove the Front Panel

- Slide the plastic trim pieces on each side of the water heater to expose the screws.
- Remove the 4 screws and pull off the front panel.

## Installation of Plumbing

### Pressure Relief Valve Requirements

Install the pressure relief valve according to local plumbing codes and these instructions.

An approved pressure relief valve is required by the *American National Standard (ANSI Z21.10.3)* for all water heating systems, and shall be accessible for servicing.

### **DO NOT**

- Do not plug the relief valve and do not install any reducing fittings or other restrictions in the relief line. The relief line should allow for complete drainage of the valve and the line.
- Do not place any other type valve or shut off device between the relief valve and the water heater.

### **MUST DO**

- The relief valve must comply with the standard for *Relief Valves and Automatic Gas Shutoff Devices for Hot Water Supply Systems ANSI Z21.22* and /or the standard *Temperature, Pressure, Temperature and Pressure Relief Valves and Vacuum Relief Valves, CAN1-4.4*.
- The relief valve must be rated up to 150 psi and to at least the maximum BTU/hr of the appliance.
- The discharge from the pressure relief valve should be piped to the ground or into a drain system to prevent exposure or possible burn hazards to humans or other plant or animal life. Follow local codes. Water discharged from the relief valve could cause severe burns instantly, scalds, or death.
- The pressure relief valve must be manually operated once a year to check for correct operation.
- The relief valve should be added to the hot water outlet line and near the hot water outlet according to the manufacturer's instructions. **DO NOT** place any other type valve or shut off device between the relief valve and the water heater.

### **INFORMATION**

- If a relief valve discharges periodically, this may be due to thermal expansion in a closed water supply system. Contact the water supplier or local plumbing inspector on how to correct this situation. Do not plug the relief valve.
- The *American National Standard (ANSI Z21.10.3)* does not require a combination temperature and pressure relief valve for this appliance. However, local codes may require a combination temperature and pressure relief valve.

### Isolation Valves

Rinnai strongly recommends the installation of isolation valves on the cold and hot water lines because they provide the ability to isolate the water heater from the structure's plumbing and allow quick access to flush the heat exchanger. Flushing the heat exchanger regularly is required as part of the proper maintenance for this water heater.

### Piping Requirements

A manual water control valve must be placed in the water inlet connection to the water heater before it is connected to the water line. Unions may be used on both the hot and cold water lines for future servicing and disconnection of the unit.

### **DO NOT**

- Do not introduce toxic chemicals such as those used for boiler water treatment to the potable water used for space heating.

### **MUST DO**

- The piping (including soldering materials) and components connected to this appliance must be approved for use in potable water systems.
- Purge the water line to remove all debris and air. Debris will damage the water heater.
- If the appliance will be used as a potable water source, it must **NOT** be connected to a system that was previously used with a non-potable water heating appliance.
- Ensure that the water filter on the water heater is clean and installed.

# Piping Diagram for Basic Installation

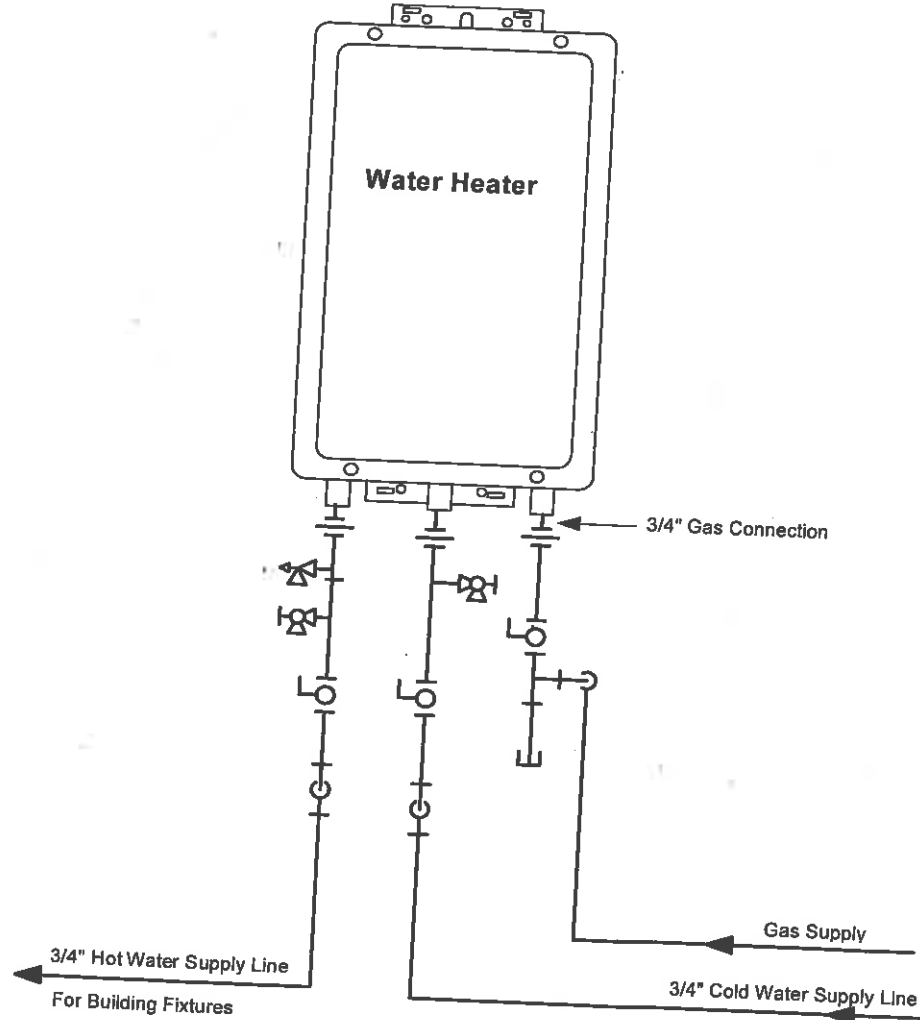

KEY	
	3/4" Ball Valve
	3/4" Union
	Check Valve
	Pressure Relief Valve
	Pressure Regulator
	Circulating Pump
	Boiler Drain Valve
	Solenoid Valve

This is not an engineered drawing. It is intended only as a guide and not as a replacement for professionally engineered project drawings. This drawing is not intended to describe a complete system. It is up to the contractor/engineer to determine the necessary components and configuration of the particular system being installed. This drawing does not imply compliance with local building code requirements. It is the responsibility of the contractor/engineer to ensure installation is in accordance with all local building codes. Confer with local building officials before installation.

## Connect Water Heater to Water Supply

Water connections to the tankless water heater should follow all state and local plumbing codes.

If this is a standard installation, refer to the Piping Diagram for Basic Installation.

1. Plumb the cold water supply to the tankless water heater on the 3/4" MNPT connection at the bottom of the unit marked "COLD."
2. Plumb the building hot water supply to the 3/4" MSPT connection marked "HOT."

If a pipe cover will be installed, make sure water lines to the water heater fit.

## Checklist for Plumbing

- Purge the water line of all debris and air by closing the hot isolation valve and opening the cold isolation valve and its drain. **Debris will damage the water heater.** Use a bucket or hose if necessary.
- Ensure that hot and cold water lines are not crossed to the unit and are leak free.
- Ensure that a pressure relief valve is installed with a rating that exceeds the BTU input of the water heater model. Refer to the rating plate on the side of the water heater for BTU input.
- Clean the inlet water filter by closing the cold and hot water inlet isolation (shut-off) valves. Put a bucket under the filter at the bottom of the water heater to catch any water that is contained inside the unit. Unscrew the water filter. Rinse the filter to remove any debris. Install the filter and open the isolation valves.
- Check for proper water pressure to the water heater. Minimum water pressure is 20 psi. Rinnai recommends 60-80 psi for maximum performance.

## Installation of Gas Supply

### **WARNING / AVERTISSEMENT**

1. If you are not knowledgeable or qualified to install gas lines or connections, then contact a licensed professional to install the gas supply.
2. Turn off 120v power supply.
3. Turn off the gas.
4. Gas is flammable. Do not smoke or provide other ignition sources while working with gas.
5. Do not turn on the water heater or gas until all fumes are gone.

## General Instructions

### MUST DO

- A manual gas control valve must be placed in the gas supply line to the water heater. A union can be used on the connection above the shut off valve for the future servicing or disconnection of the unit.
- Check the type of gas and the gas inlet pressure before connecting the water heater. If the water heater is not of the gas type that the building is supplied with, **DO NOT** connect the water heater. Contact the dealer for the proper unit to match the gas type.
- Check the gas supply pressure immediately upstream at a location provided by the gas company. Supplied gas pressure must be within the limits shown in the Specifications section with all gas appliances operating.
- Before placing the appliance in operation all joints including the heater must be checked for gas tightness by means of leak detector solution, soap and water, or an equivalent nonflammable solution, as applicable. (Since some leak test solutions, including soap and water, may cause corrosion or stress cracking, the piping shall be rinsed with water after testing, unless it has been determined that the leak test solution is non-corrosive.)
- Use approved connectors to connect the unit to the gas line. Purge the gas line of any debris before connection to the water heater.

- Any compound used on the threaded joint of the gas piping shall be a type which resists the action of liquefied petroleum gas (propane / LPG).
- The gas supply line shall be gas tight, sized, and so installed as to provide a supply of gas sufficient to meet the maximum demand of the heater and all other gas consuming appliances at the location without loss of pressure.

**INFORMATION**

- Refer to an approved pipe sizing chart if in doubt about the size of the gas line.

**Size the gas pipe**

The gas supply must be capable of handling the entire gas load at the location. Gas line sizing is based on gas type, the pressure drop in the system, the gas pressure supplied, and gas line type. For gas pipe sizing in the United States, refer to the *National Fuel Gas Code, NFPA 54*. The below information is provided as an example. The appropriate table from the applicable code must be used.

1. For some tables, you will need to determine the cubic feet per hour of gas required by dividing the gas input by the heating value of the gas (available from the local gas company). The gas input needs to include all gas products at the location and the maximum BTU usage at full load when all gas products are in use.
2. Use the table for your gas type and pipe type to find the pipe size required. The pipe size must be able to provide the required cubic feet per hour of gas or the required BTU/hour.

$$\text{Cubic Feet per Hour (CFH)} = \frac{\text{Gas Input of all gas products (BTU / HR)}}{\text{Heating Value of Gas (BTU / FT}^3\text{)}}$$

Example:

The heating value of natural gas for your location is 1000 BTU/FT<sup>3</sup>. The gas input of the V53De is 120,000 BTU/HR. Additional appliances at the location require 65,000 BTU/hr. Therefore the cubic feet per hour = (120,000 + 65,000) / 1000 = 185 FT<sup>3</sup>/HR. If the pipe length is 20 feet then the 3/4 inch pipe size is capable of supplying 188 FT<sup>3</sup>/HR of natural gas.

**Pipe Sizing Table - Natural Gas**

Schedule 40 Metallic Pipe

Inlet Pressure: less than 2 psi (55 inches W.C.)

Pressure Drop: 0.3 inches W.C.

Specific Gravity: 0.60

cubic feet per hour

Length	Pipe Size (inches)			
	3/4	1	1 1/4	1 1/2
10	273	514	1060	1580
20	188	353	726	1090
30	151	284	583	873
40	129	243	499	747
50	114	215	442	662
60	104	195	400	600
70	95	179	368	552
80	89	167	343	514
90	83	157	322	482
100	79	148	304	455

**Pipe Sizing Table - Propane Gas**

Schedule 40 Metallic Pipe

Inlet Pressure: 11.0 inches W.C.

Pressure Drop: 0.5 inches W.C.

Specific Gravity: 1.50

Capacity in Thousands of BTU per Hour

Length	Pipe Size (inches)			
	1/2	3/4	1	1 1/4
10	291	608	1150	2350
20	200	418	787	1620
30	160	336	632	1300
40	137	287	541	1110
50	122	255	480	985
60	110	231	434	892
80	101	212	400	821
100	94	197	372	763

## Connect Electricity

### **⚠️ WARNING / AVERTISSEMENT**

Do not use an extension cord or an adapter plug with this appliance.

The water heater must be electrically grounded in accordance with local codes and ordinances or, in the absence of local codes, in accordance with the National Electrical Code, ANSI/NFPA No. 70.

Do not rely on the gas or water piping to ground the water heater. A screw is provided in the junction box for the grounding connection.

The water heater requires 120 VAC, 60 Hz power from a properly grounded circuit.

A disconnect switch must be provided and installed for the incoming 120 VAC power. It should be a type that is suitable for outdoor use. Check the National Electrical Code, ANSI/NFPA 70 and your local codes for a proper switch type to use in your area.

The wiring diagram is located on the Technical Sheet attached to the inside of the front cover.

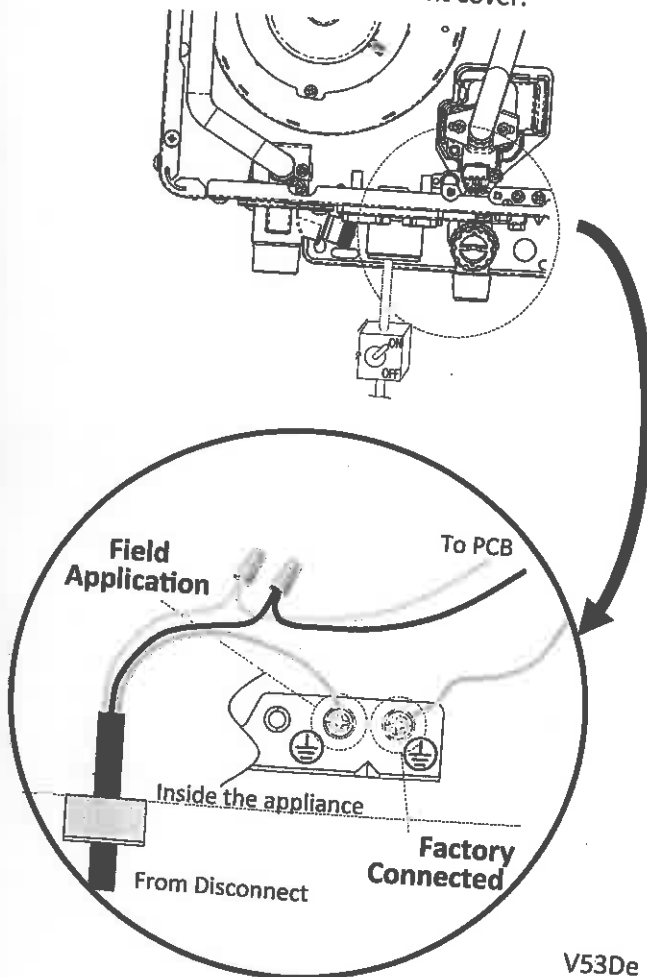

## Adjust for High Altitude

On the Dip switches, set switches No. 2 and No. 3 to the values shown in table below for your altitude. The default setting for the appliance is 0-2000 ft (0-610 m) with switches No. 2 and No. 3 in the OFF position.

When the Dip switch is adjusted, it is not necessary to adjust the gas pressure setting for high altitude.

Altitude	Switch No. 2	Switch No. 3
0-2000 ft (0-610 m)	OFF	OFF
2001-5200 ft (610-1585 m)	OFF	ON
5201-7700 ft (1585-2347 m)	ON	OFF
7701-10200 ft (2347-3109 m)	ON	ON

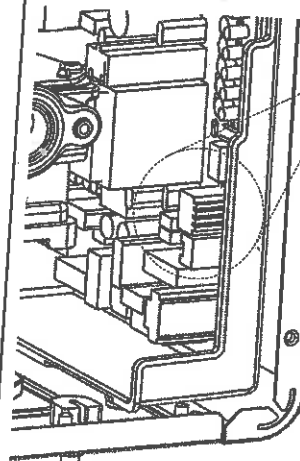

Dip Switch Location

Switch Functions	
SW1	No Function
SW2	High Alt.
SW3	High Alt.
SW4	Gas ON/OFF

## Checklist for Gas and Electricity

- A manual gas control valve is placed in the gas line to the water heater.
- Check the gas lines and connections for leaks.
- Confirm that the gas inlet pressure is within limits.
- Confirm that the water heater is rated for the gas type supplied.
- Confirm that the electricity is supplied from 120 VAC, 60 Hz power source and is in a properly grounded circuit.
- An extension cord or an adapter plug has not been used with the water heater.

## Installation of Temperature Controller

### **⚠ WARNING / AVERTISSEMENT**

Turn the power off. Do not attempt to connect the temperature controllers with the power on. Although the controller is a low voltage device, there is 120 volt potential next to the temperature controller connections inside the unit.

Do not connect the temperature controller to the 120VAC terminals provided for the optional solenoid drain valves.

### Controller Location

- The controller should be out of reach of small children.
- Avoid locations where the controller may become hot (near the oven or radiant heater).
- Avoid locations in direct sunlight. The digital display may be difficult to read in direct sunlight.
- Avoid locations where the temperature controller could be splashed with liquids.
- Do not install in locations where it can be adjusted by the public.

### Cable Lengths and Sizes

The cable for the temperature controller should be a non-polarized two-core cable with a minimum gauge of 22 AWG. The maximum cable length from each controller to the water heater depends on the total number of wired controllers connected to the water heater.

Number of Wired Controllers	Maximum Cable Length for each Controller to Water Heater
1	328 ft (100 m)
2	164 ft (50 m)
3 or 4	65 ft (20 m)

### Configurations

A maximum of 4 temperature controllers can be installed for a water heater or bank of water heaters. This includes the controller built into an indoor water heater. Controllers can only be wired in parallel. Controllers cannot be wired in series.

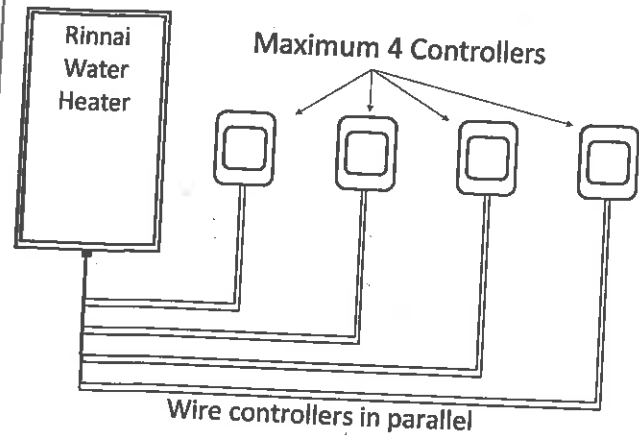

If 4 MC-601-US controllers are installed, simultaneously press the Priority and ON/OFF buttons on the fourth controller until a beep sounds.

Residential Applications: MC-601-US-BK,  
MC-601-US-W

## Mounting the Controller

Follow the procedure below to install an MC-601-US temperature controller.

1. Determine a suitable location for the controller.
2. Make three holes in the wall as shown.

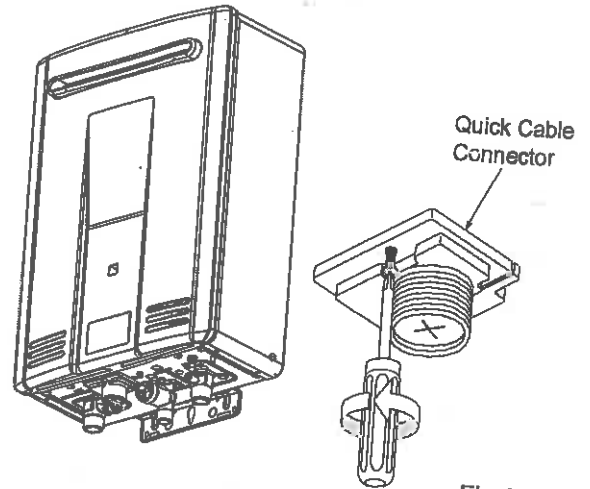
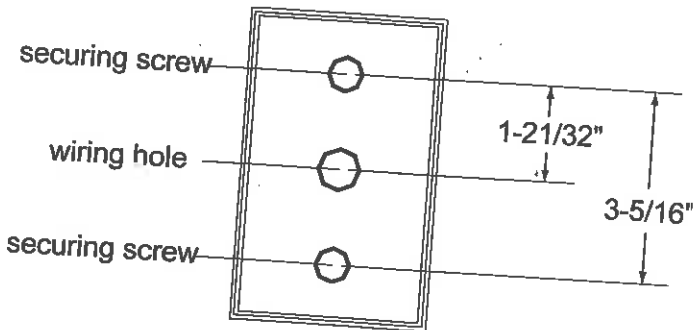

Fig.1

3. Run the wiring between the controller and the Rinnai water heater or the controller and another controller as shown in the illustration on P.14.
4. Remove the face plate from temperature controller using a screwdriver.
5. Connect the cable to the temperature controller (refer to remote controller installation instructions for details).
6. Mount the controller to the wall using the holes drilled in step 2.
7. Disconnect power from the water heater.
8. Remove the screw on the Quick Cable Connector. (Fig. 1)
9. Rotate the Quick Cable Connector. (Fig. 2)
10. Route the wires through the Cable Access Hole (Fig. 2)
11. Loosen the clamp screw and secure the wires with the clamp. The clamp is in the box with the temperature controller. Make sure the wire lengths are of sufficient length. There should be no tension in the wires. (Fig. 3)
12. Loosen 2 screws on the terminals for controls and connect the cable (polarity is unimportant, either color can be connected to either terminal). When connecting more than 2 cables, connect them in parallel. (Fig. 4)
13. Reinstall the Quick Cable Connection. (Fig. 5)

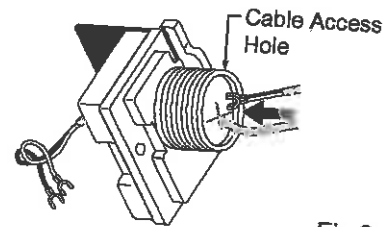

Fig.2

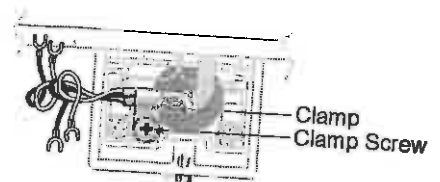

Fig.3

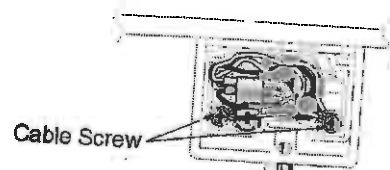

Fig.4

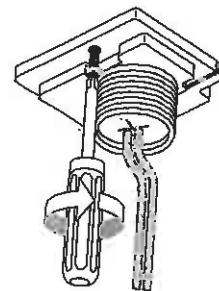

Fig.5

## Final Checklist

- The water heater is not subject to corrosive compounds in the air.
- The water supply does not contain chemicals or exceeds total hardness that will damage the heat exchanger.
- Clearances from the water heater unit are met.
- Clearances from the exhaust outlet / air intake are met.
- Purge the water line of all debris and air by closing the hot isolation valve and opening the cold isolation valve and its drain. **Debris will damage the water heater.** Use a bucket or hose if necessary.
- Ensure that hot and cold water lines are not crossed to the unit and are leak free.
- Clean the inlet water filter by closing the cold and hot water inlet isolation (shut-off) valves. Put a bucket under the filter at the bottom of the water heater to catch any water that is contained inside the unit. Unscrew the water filter. Rinse the filter to remove any debris. Install the filter and open the isolation valves.
- Ensure that a pressure relief valve is installed with a rating that exceeds the BTU input of the water heater model. Refer to the rating plate on the side of the water heater for BTU input.
- A manual gas control valve has been placed in the gas line to the water heater.
- Check the gas lines and connections for leaks.
- Confirm that the gas inlet pressure is within limits.
- Confirm that the water heater is rated for the gas type supplied.
- Confirm that the electricity is supplied from a 120 VAC, 60 Hz power source, is in a properly grounded circuit, and turned on.
- Verify the temperature controller is functioning properly.
- Verify that Dip switches No. 2 and No. 3 are set correctly for your altitude.
- Verify the system is functioning correctly by connecting your manometer to the gas pressure test port on the water heater. Operate all gas appliances in the home or facility at high fire. The inlet gas pressure at the water heater must not drop below that listed on the rating plate.
- If the water heater is not needed for immediate use, then drain the water from the heat exchanger.
- Install the front panel.
- Explain to the customer the importance of not blocking the exhaust outlet or air intake.
- Explain to the customer the operation of the water heater, safety guidelines, maintenance, and warranty.
- The installation must conform with local codes or, in the absence of local codes, with the *National Fuel Gas Code, ANSI Z223.1/NFPA 54*, or the *Natural Gas and Propane Installation Code, CSA B149.1*. If installed in a manufactured home, the installation must conform with the *Manufactured Home Construction and Safety Standard, Title 24 CFR, Part 3280* and/or *CAN/SCA Z240 MH Series, Mobile Homes*.
- Leave the entire manual taped to the temperature controller (if installed), or give the entire manual directly to the consumer.**



## Technical Data

### Specifications

		<b>V53De</b>
Minimum Gas Consumption Btu/h		15,500 (LP & NG Both)
Maximum Gas Consumption Btu/h		120,000
Hot water capacity (Min - Max) *		0.4 - 5.3 GPM (1.5 - 20.0 L/min)
Temperature Settings (without temperature controller)		120° F (49° C), default or 140° F (60° C)
Temperature Controller Default Setting		115° F (46° C)
Maximum Temp Setting (residential) see Temperature Ranges for more information		140° F (60° C)
Minimum Temperature Setting		115° F (46° C)
Weight		29.7 lb. (13.5 kg)
Noise level		54 dB
Electrical Consumption	Normal	50W
	Standby	2 W
	Anti-frost Protection	64W
	Max Current	1.2A
	Fuse	5A
By-Pass Control		Fixed
Gas Supply Pressure	Natural Gas	4.5 - 10.5 inch W.C.
	Propane	8.0 - 13.5 inch W.C.
Type of Appliance		Temperature controlled continuous flow gas hot water system.
Connections		Gas Supply: 3/4" MNPT, Cold Water Inlet: 3/4" MNPT, Hot Water Outlet: 3/4" MNPT
Ignition System		Direct Electronic Ignition
Electric Connections		Appliance: AC 120 Volts, 60Hz. Remote Control: DC 12 Volts (Digital)
Water Temperature Control		Simulation Feedforward and Feedback.
Water Supply Pressure		Minimum Water Pressure: 20 PSI (Recommended 30-80 PSI for maximum performance)
Maximum Water Supply Pressure		150 PSI
Remote Control Cable		Non-Polarized Two Core Cable (Minimum 22 AWG)
Certified for installation in manufactured (mobile) homes		Yes
NOx		Complies with South Coast Air Quality Management District 40 ng/J NOx emission levels

\* Minimum flow may vary slightly depending on the temperature setting and the inlet water temperature.  
Minimum activation flow is 0.6 GPM (1.5 L/min).

Our products are continually being updated and improved; therefore, specifications are subject to change without prior notice.  
The maximum inlet gas pressure must not exceed the value specified by the manufacturer. The minimum value listed is for the purpose of input adjustment.

## Dimensions

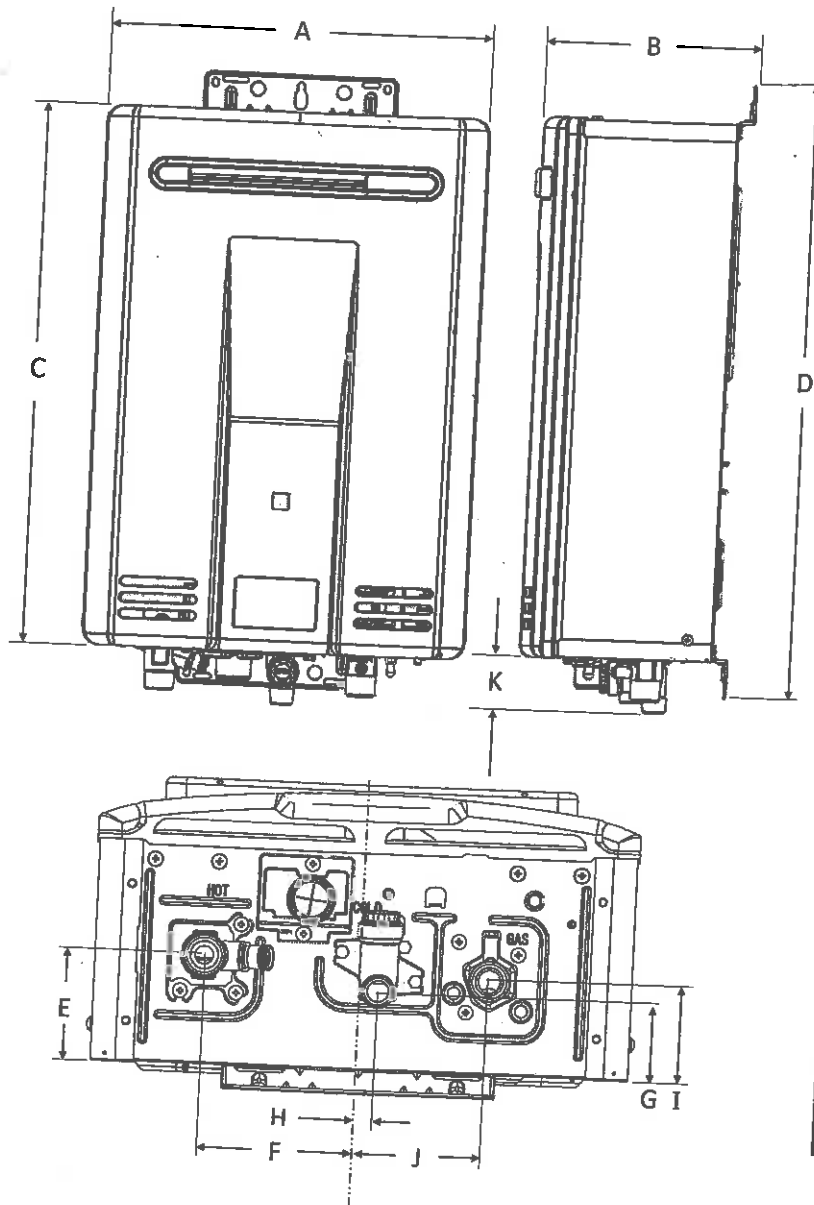

DIM	DESCRIPTION	V53De in (mm)
A	Width	14.0 (356)
B	Depth *	7.9 (202)
C	Height - Unit	19.8 (503)
D	Height - with brackets	22.5 (571)
E	Hot Water Outlet - from wall *	3.4 (87)
F	Hot Water Outlet - from center	4.1 (105)
G	Cold Water Inlet - from wall *	2.7 (68)
H	Cold Water Inlet - from center	0.4 (10)
I	Gas Connection - from wall *	3.0 (77)
J	Gas Connection - from center	3.3 (83)
K	From base to gas connection	1.6 (40)
	From base to cold connection	2.0 (50)
	From base to hot connection	1.5 (39)

### Pressure Drop Curve

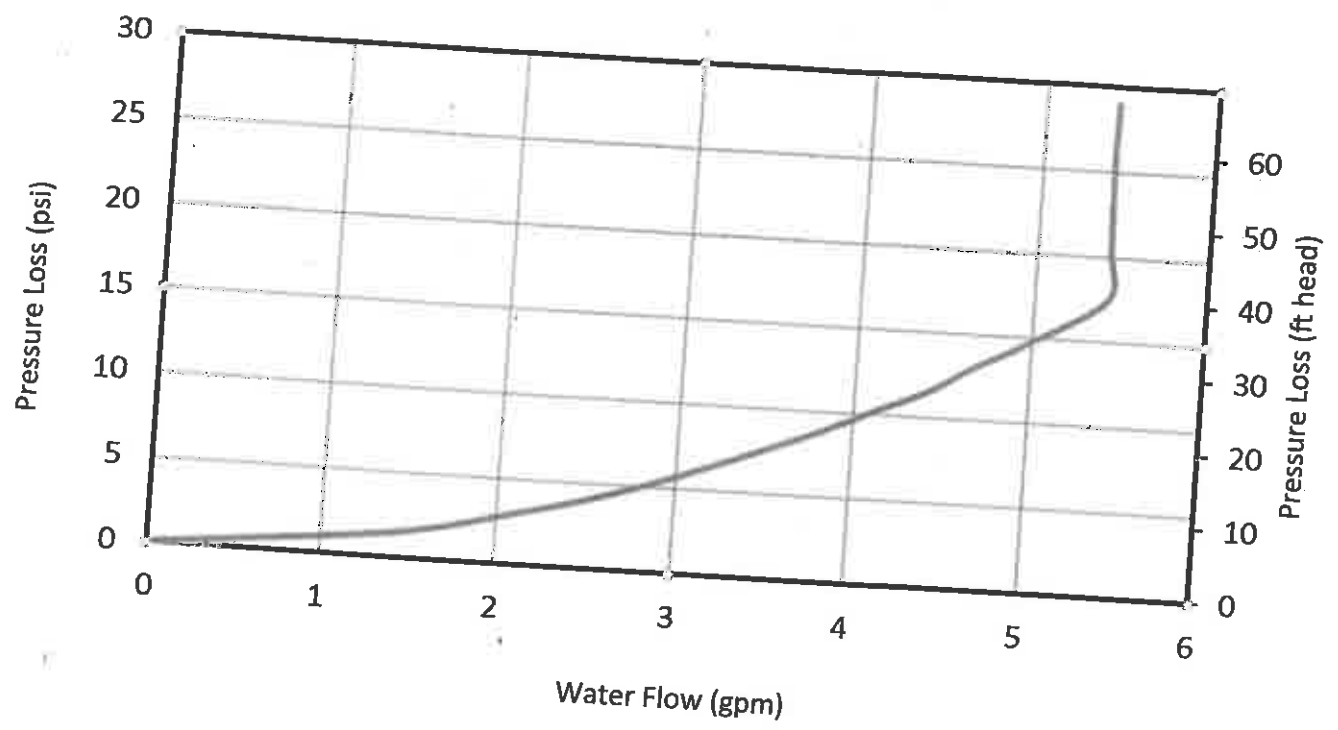

### Water Flow Curve

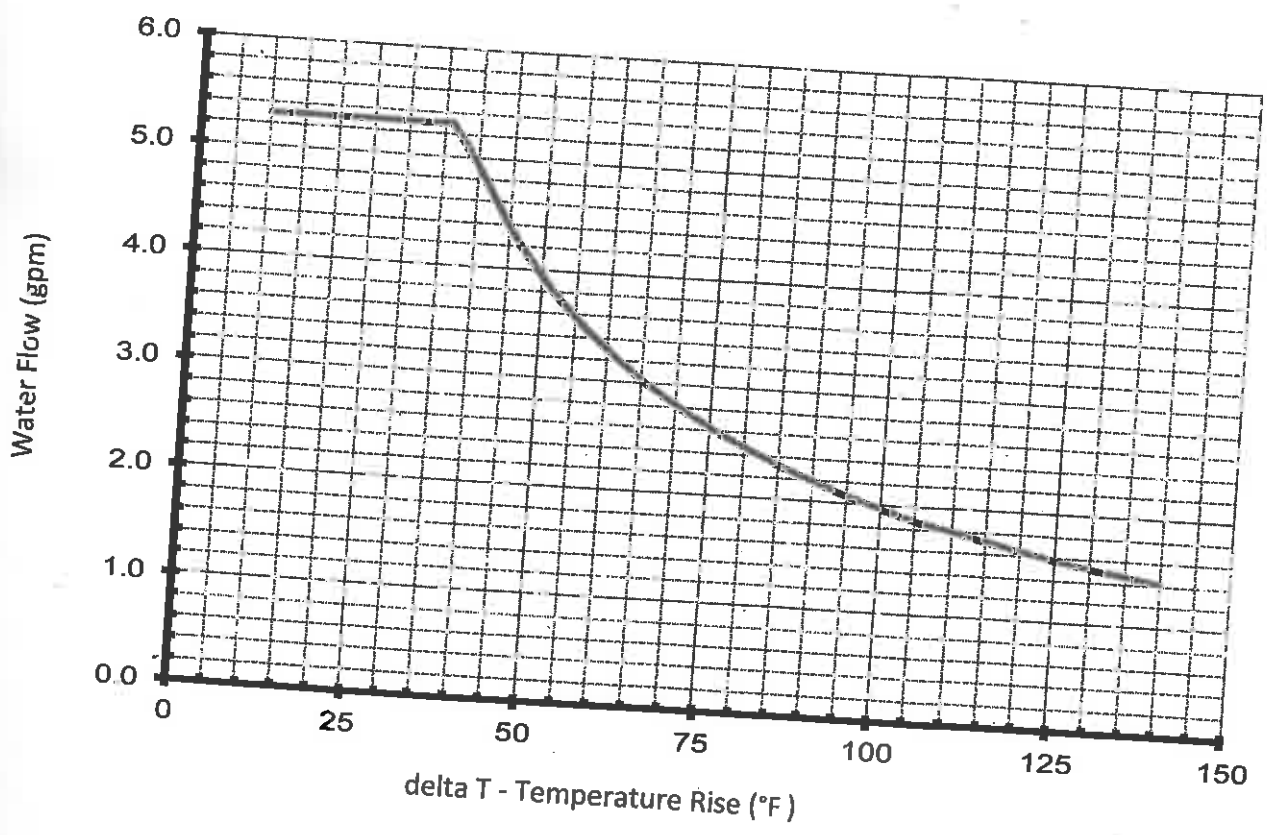

# Ladder Diagram

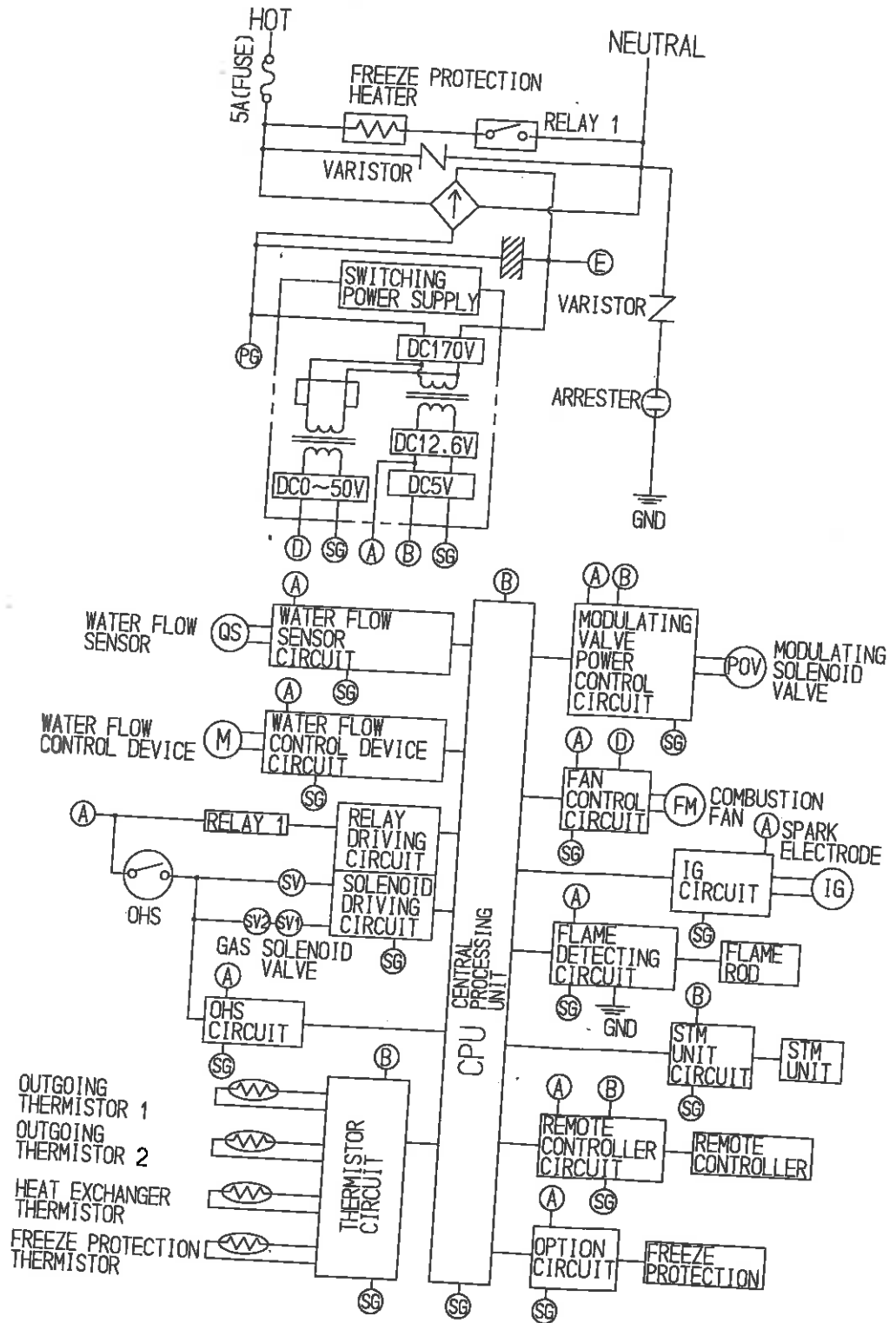

# Rinnai®

## Outdoor Tankless Water Heater Operation Instructions

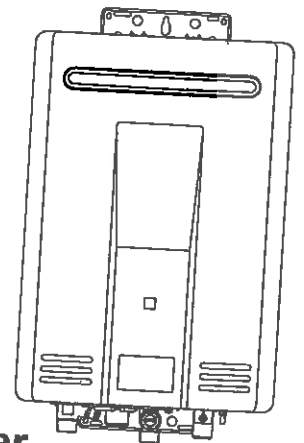

**FOR OUTDOOR APPLICATIONS ONLY**  
V53De ..... REU-AM1620WD-US

### Important Facts about your Water Heater

Thank you for purchasing a Rinnai Tankless Water Heater. For proper operation and safety, it is important to follow the instructions and adhere to the safety precautions.

Read all of the instructions and the warranty thoroughly before operating this water heater. Keep this manual in a safe place.

NOTICE: Rinnai sometimes shares customer contact information with businesses that we believe provide products or services that may be useful to you. By providing this information, you agree that we can share your contact information for this purpose. If you prefer not to have your information shared with these businesses, please contact customer service and ask not to have your information shared. We will however, continue to contact you with information relevant to the product(s) you registered and/or you account with us.

**⚠ WARNING** If the information in these instructions is not followed exactly, a fire or explosion may result causing property damage, personal injury or death.

**⚠ AVERTISSEMENT** Assurez-vous de bien suivre les instructions données dans cette notice pour réduire au minimum le risque d'incendie ou d'explosion ou pour éviter tout dommage matériel, toute blessure ou la mort.

- Do not store or use gasoline or other flammable vapors and liquids in the vicinity of this or any other appliance.
- **WHAT TO DO IF YOU SMELL GAS**
  - Leave the premises.
  - Do not try to light any appliance.
  - Do not touch any electrical switch; do not use any phone in your building.
  - Immediately call your gas supplier from a neighbor's phone. Follow the gas supplier's instructions.
  - If you cannot reach your gas supplier, call the fire department.
- Installation and service must be performed by a licensed professional.

# Consumer Operation Guidelines for the Safe Operation of your Water Heater

FOR YOUR SAFETY READ BEFORE OPERATING

**WARNING**

**AVERTISSEMENT**

If you do not follow these instructions exactly, a fire or explosion may result causing property damage, personal injury or loss of life.

A. This appliance does not have a pilot. It is equipped with an ignition device which automatically lights the burner. Do not try to light the burner by hand.

B. BEFORE OPERATING, smell all around the appliance area for gas. Be sure to smell next to the floor because some gas is heavier than air and will settle on the floor.

### WHAT TO DO IF YOU SMELL GAS:

- Do not try to light any appliance.
- Do not touch any electric switch; do not use any phone in your building.
- Immediately call your gas supplier from a neighbor's phone. Follow the gas supplier's instructions.

• If you cannot reach your gas supplier, call the fire department.

C. Use only your hand to push in or turn the gas control knob. Never use tools. If the knob will not push in or turn by hand, do not try to repair it, call a qualified licensed professional. Force or attempted repair may result in a fire or explosion.

D. Do not use this appliance if any part has been under water. Immediately call a qualified licensed professional to inspect the appliance and to replace any part of the control system and any gas control which has been under water.

## OPERATING INSTRUCTIONS

1. **STOP!** Read the safety information above.
2. Set the thermostat to lowest setting.
3. Turn off electric power to the appliance using the ON/OFF button.
4. This appliance is equipped with an ignition device which automatically lights the burner. Do not try to light the burner by hand.
5. Turn the gas valve clockwise to the full OFF position.

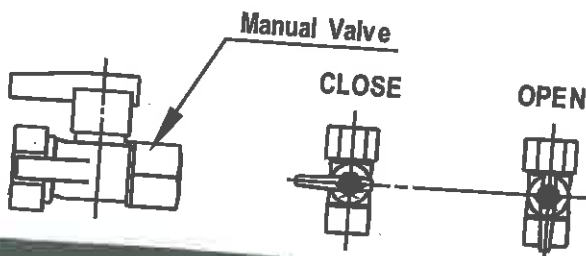

6. Wait five (5) minutes to clear out any gas. Then smell for gas, including near the floor. If you smell gas, STOP! Follow "B" in the safety information above. If you don't smell gas, go to the next step.
7. Turn the gas valve counterclockwise to the full ON position.
8. Turn on electric power to the appliance using the ON/OFF button.
9. Set the thermostat to desired setting.
10. Open a hot water tap. If the appliance will not operate, follow the instructions "To Turn Off Gas To Appliance" and call your licensed professional or gas supplier. See manual for additional information.

## TO TURN OFF GAS TO APPLIANCE

1. Turn off all electric power to the appliance using the ON/OFF button.
2. Set the thermostat to lowest setting.
3. Turn the gas valve clockwise to the full OFF position.

## How to Use the Temperature Controller

Dimensions (inches): 3.54 W x 4.72 H x 0.70 D  
90mm x 120mm x 17.7mm

The V53De does not come with a temperature controller. There are several models of temperature controllers that can be purchased separately.

A maintenance display or status monitor is provided in the front panel to indicate operating status and error codes.

The MC-601-US controller is the standard temperature controller.

DO NOT repeatedly operate the water heater and then use a hot water tap while the controller is turned off. Operating the water heater in this way to alternately produce hot water may cause water to condense on the outside of internal parts and accumulate in the water heater cabinet.

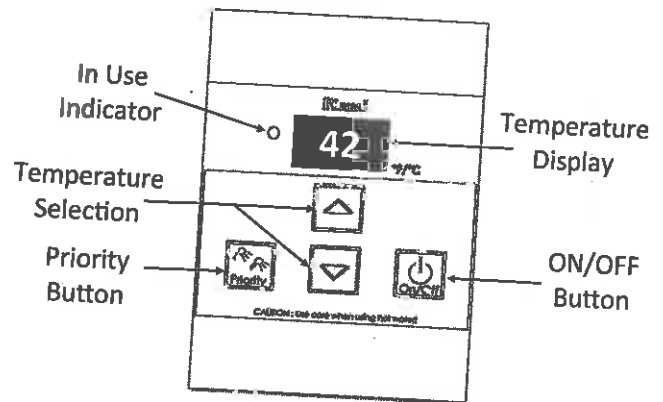

### **WARNING / AVERTISSEMENT**

- Before operating, smell all around the appliance area for gas. Be sure to smell next to the floor because some gas is heavier than air and will settle on the floor.
- Keep the area around the appliance clear and free from combustible materials, gasoline, and other flammable vapors and liquids.
- Always check the water temperature before entering a shower or bath.
- Do not use this appliance if any part has been under water. Immediately call a licensed professional to inspect the appliance and to replace any part of the control system and any gas control which has been under water.
- Should overheating occur or gas supply fail to shut off, turn off the manual gas control valve to the appliance.
- Do not adjust the Dip Switch unless specifically instructed to do so.
- Do not use an extension cord or an adapter plug with this appliance.
- Any alteration to the appliance or its controls can be dangerous and will void the warranty.
- If you install this water heater in an area that is known to have hard water or that causes scale build-up the water must be treated and/or the heat exchanger flushed regularly. Rinnai provides a "Scale Control System" that offers superior lime scale prevention and corrosion control by feeding a blend of control compounds into the water supply. Damage and repair due to corrosive compounds in the air is not covered by warranty.
- Keep the air intake location free of chemicals such as chlorine or bleach that produce fumes. These fumes can damage components and reduce the life of your appliance. Damage and repair due to scale in the heat exchanger is not covered by warranty.

## How to Set the Temperature

This water heater requires a minimum flow rate to operate. This rate can be found on the specification page in this manual. In some cases when you are not getting hot water or if the water alternates between hot and cold it is due to the water flow being below or close to the minimum flow rate. Increasing the flow rate should resolve these problems in these cases.

If you are experiencing issues with higher temperature settings, then reduce the temperature setting. Selecting temperature closer to that which is actually used at the faucet will increase the amount of hot water being delivered to the faucet, due to less cold water mixing at the fixture.

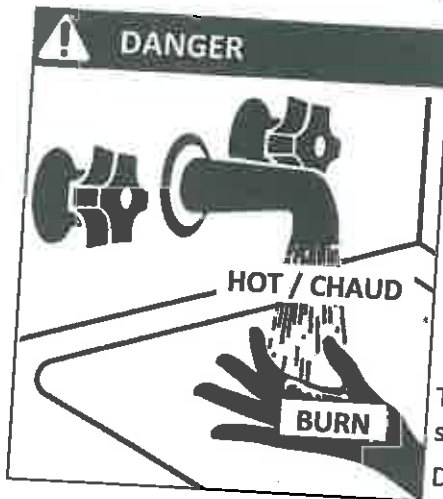

Hot water can be dangerous, especially for infants or children, the elderly, or infirm. There is hot water scald potential if the thermostat is set too high. Water temperatures over 125° F (52° C) can cause severe burns or scalding resulting in death.

Hot water can cause first degree burns with exposure for as little as:

3 seconds at 140° F (60° C)

20 seconds at 130° F (54° C)

8 minutes at 120° F (49° C)

Test the temperature of the water before placing a child in the bath or shower.

Do not leave a child or an infirm person in the bath unsupervised.



1. If the water heater is off, press the Power button to turn on.
2. If the Priority light is off, then press the "Priority button" on the temperature controller. The green Priority light will glow indicating that this controller is controlling the temperature and that the water heater is ready to supply hot water. (The priority can only be changed while no hot water is running.)
3. Press the up or down buttons to obtain the desired temperature setting.



All hot water sources are able to provide water at this temperature setting until it is changed again at this or another temperature controller.

**NOTICE** While any hot water is being provided, the temperature setting cannot be set any lower than 115° F.

**NOTICE** Check local codes for the maximum water temperature setting allowed when used in nursing homes, schools, day care centers, and all other public applications.

**NOTICE** If a newly installed unit with a controller has not been powered for at least 6 hours then the temperature will return to the default setting of 115° F (46° C) if power is interrupted.

**NOTICE** There may be a variation between the temperature displayed on the temperature controller and the temperature at the tap due to weather conditions or the length of pipe to the water heater.



## Temperatures Available with a Controller

The water heater can deliver water at only one temperature setting at a time. The available temperatures are provided below. A temperature lower than 115° F (46° C) can be obtained at the tap by mixing with cold water. To change the temperature scale from Celsius to Fahrenheit or vice versa, press and hold the ON/OFF button for 5 seconds while the water heater is OFF.

V53De	Temperature Settings Available (°F)					
	115	120	125	130	135	140
Temp in Celsius °C	46	49	52	54	57	60

Water temperatures over 125°F (52°C) can cause severe burns or scalding. Refer to the Danger Alert on water temperatures. Rinnai shall not, in any event, be liable for damages resulting from such misuse or misapplication.

 <b>WARNING / AVERTISSEMENT</b>	DO NOT adjust the other switches unless specifically instructed to do so.
--	---

These temperatures are suggestions only:

- Kitchen 120 °F (49° C)
- Shower 98 - 110 °F (37 - 43 °C)

### Setting Controller to Mute

On the MC-601-US to eliminate the beeps when keys are pressed or to turn the beeps back on, press and hold both the up and down buttons until a beep is heard (approximately 5 seconds).

### Locking the Controller

The MC-601-US controller can be locked by pressing the Priority button and the up button together for 5 seconds. A beep will sound confirming that the controller is locked. The display will alternately show "LOC", the temperature setting, and a diagnostic code if one has been activated. All of the controllers in the system are also locked.

To unlock the controller press the Priority button and the up button together for 5 seconds.

## Temperature Options Without a Temperature Controller

The default temperature setting for this appliance installed without a temperature controller is 120° F (49° C). If desired, the temperature setting can be changed to 140° F (60° C), as well as other temperature increments by push button adjustments, as described below.

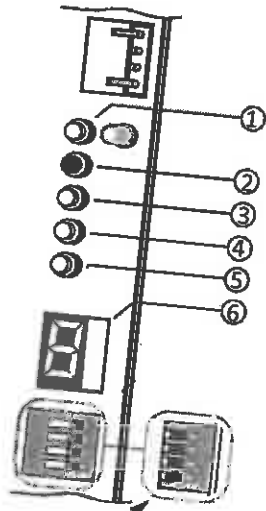

DipSwitch detail when viewed from the front

### PCB Interface Layout and Functions

1. **Push Button 1 (PB1) - White**  
Data transfer button for PCB replacement.
2. **Push Button 2 (PB2) - Black**  
MODE button - places PCB in programming mode.
3. **Push Button 3 (PB3) - White**  
MENU button - cycles through available menus 1, 2, 3, 4, 5 and 6 (see table below).
4. **Push Button 4 (PB4) - White**  
VALUE button - cycles through available menu values (see table below).
5. **Push Button 5 (PB5) - White**  
Forced High/Low selection rate setting
6. **LED Digital Display**  
Displays MENU (1, 2, etc.), VALUE (R, b, etc.) and Forced Low/High status (L or H).

### Programming Parameters



Menu #	Menu Description	Value			
		R	b	L	d
1	Gas Type	LPG		NG	
2	Model Type	1620			
3	Fixed Temperatures	120°F 48.9°C	140°F 60°C		
4	Max Temperature Setting of Controller(s)	120°F 48.9°C	140°F 60°C		
5	OFF Water Flow Rate	+5°F +3°C	+11°F +6°C		
6	Adjustment due to piping heat loss	+0°F +0°C	+2°F +1°C	+4°F +2°C	+5°F +3°C

## Diagnostic Codes

This water heater is designed to display diagnostic codes. If there is a potential operation concern refer to the code and remedy on the next page.

### Front Panel Display Indications

--	Standby (power is supplied but there is no demand for hot water).
On	Hot water is being supplied.
FL or FH	Stands for Forced Low and Forced High combustion. Only seen during the gas pressure setting procedure which is done when certain components are replaced.
Error code flashing	The error code will stop flashing after the problem is corrected and the water heater supplies hot water.

 <b>WARNING</b>	Some of the checks below may need to be done by a licensed professional. Call a licensed professional for any remedy that involves gas or electricity. Call a licensed professional if you have any doubt or reservation about performing the remedy yourself.
 <b>AVERTISSEMENT</b>	

Code	Definition	Remedy
02	No burner operation during freeze protection mode	Service Call
10	Air Supply or Exhaust Blockage	Check that nothing is blocking the inlet or exhaust.
		licensed professional only Verify dip switches and programming parameters are set properly Check fan for blockage
11	No Ignition (heater not turning on)	Check that the gas is turned on at the water heater, gas meter, or cylinder. If the system is propane, make sure that gas is in the tank. Ensure appliance is properly grounded.
		licensed professional only Ensure gas type and pressure is correct Ensure gas line, meter, and/or regulator is sized properly Bleed all air from gas lines. Verify dip switches and programming parameters are set properly Ensure igniter is operational Check igniter wiring harness for damage Check gas solenoid valves for open or short circuits Remove burner cover and ensure all burners are properly seated Remove burner plate and inspect burner surface for condensation or debris Check the ground wire for the PC board
12	No Flame	Check that the gas is turned on at the water heater, gas meter, or cylinder. Check for obstructions in the flue outlet. If the system is propane, make sure that gas is in the tank.
		licensed professional only Ensure gas line, meter, and/or regulator is sized properly. Ensure gas type and pressure is correct Bleed all air from gas lines Ensure condensation coil was installed properly Verify dip switches and programming parameters are set properly Check power supply for loose connections Check power supply for proper voltage and voltage drops Ensure flame rod wire is connected Check flame rod for carbon build-up Disconnect and reconnect all wiring harnesses on unit and PC board Check for DC shorts at components Check gas solenoid valves for open or short circuits Remove burner plate and inspect burner surface for condensation or debris

Code	Definition		Remedy
14	Thermal Fuse has activated	licensed professional only	<p>Check for restrictions in air flow around unit and exhaust outlet.</p> <p>Check gas type of unit and ensure it matches gas type being used</p> <p>Check for low water flow in a circulating system causing short-cycling</p> <p>Ensure dip switches and programming parameters are set to the proper position</p> <p>Check for foreign materials in combustion chamber and/or exhaust piping</p> <p>Check heat exchanger for cracks and/or separations</p> <p>Check heat exchanger surface for hot spots which indicate blockage due to scale build-up. Refer to instructions in manual for flushing heat exchanger. Hard water must be treated to prevent scale build up or damage to the heat exchanger.</p> <p>Measure resistance of safety circuit.</p> <p>Ensure high fire and low fire manifold pressure is correct.</p> <p>Check for improper conversion of product.</p>
16	Over Temperature Warning (safety shutdown because unit is too hot)		<p>Check for restrictions in air flow around unit and exhaust outlet.</p> <p>Check for low water flow in a circulating system causing short-cycling</p> <p>Check for foreign materials in combustion chamber and/or exhaust piping.</p> <p>Check for blockage in the heat exchanger.</p>
19	Electrical Grounding		<p>Check all components for electrical short</p>
32	Outgoing Water Temperature Sensor		<p>Check sensor wiring for damage.</p> <p>Measure resistance of sensor</p> <p>Clean sensor of scale build-up</p> <p>Replace sensor.</p>
33	Heat Exchanger Outgoing Temperature Sensor		<p>Check sensor wiring for damage.</p> <p>Measure resistance of sensor</p> <p>Clean sensor of scale build-up.</p> <p>Replace sensor.</p>
41	Outside temperature thermistor	licensed professional only	<p>Check modulating gas solenoid valve wiring harness for loose or damaged terminals.</p> <p>Measure resistance of valve coil</p>
52	Modulating Solenoid Valve Signal		<p>Ensure fan will turn freely</p> <p>Check wiring harness to motor for damaged and/or loose connections</p> <p>Measure resistance of motor winding</p>
61	Combustion Fan		<p>Replace the PC Board</p>
70	PC Board		<p>Replace the PC Board</p>
71	Solenoid Valve Circuit		<p>Verify flame rod is touching flame when unit fires</p> <p>Check all wiring to flame rod</p> <p>Remove flame rod and check for carbon build-up, clean with sand paper.</p> <p>Check inside burner chamber for any foreign material blocking flame at flame rod.</p> <p>Measure micro amp output of sensor circuit with flame present.</p> <p>Replace flame rod</p>
72	Flame Sensing Device		<p>LC0~LC9 indicates that there is scale build up in the heat exchanger and that the heat exchanger needs to be flushed to prevent damage. Refer to flushing instructions in manual. <b>Hard water must be treated to prevent scale build up or damage to the heat exchanger.</b></p> <p>To operate the water heater temporarily until the heat exchanger can be flushed, push the On/Off button on the temperature controller 5 times. Repeated LC codes will eventually lockout the water heater.</p>
LC# LCQ LC...	Scale Build-up in Heat Exchanger (when checking maintenance code history, "00" is substituted for "LC")		<p>Please call Rinnai technical department.</p>
FF	Maintenance Indicator		<p>Placeholder in Diagnostic code history indicating that a service provider performed maintenance or service.</p> <p>Enter this code after performing service by pressing ▲(Up), ▼(Down) and ON/OFF consecutively. FF is visible on the monitor.</p>
No code	Nothing happens when water flow is activated.	licensed professional only	<p>Clean inlet water supply filter.</p> <p>On new installations ensure hot and cold water lines are not reversed.</p> <p>Verify you have at least the minimum flow rate required to fire unit.</p> <p>Check for cold to hot cross over. Isolate circulating system if present. Turn off cold water to the unit, open pressure relief valve, if water continues to flow, there is bleed over in your plumbing.</p> <p>Verify turbine spins freely</p> <p>Measure the resistance of the water flow control sensor</p> <p>If the display is blank and clicking is coming from the unit, disconnect the water flow servo motor. If the display comes on then replace the water flow servo motor.</p>

\* See "Electrical Diagnostics" on Technical Data Sheet located inside the front cover of water heater.

## Required Maintenance

The appliance must be inspected annually by a licensed professional. Repairs and maintenance should be performed by a licensed professional. The licensed professional must verify proper operation after servicing.

### **⚠ WARNING / AVERTISSEMENT**

To protect yourself from harm, before performing maintenance:

- Turn off the electrical power supply by unplugging the power cord or by turning off the electricity at the circuit breaker. (The temperature controller does not control the electrical power.)
- Turn off the gas at the manual gas valve, usually located immediately below the water heater.
- Turn off the incoming water supply. This can be done at the isolation valve immediately below the water heater or by turning off the water supply to the building.

### **⚠ WARNING / AVERTISSEMENT**

Keep the appliance area clear and free from combustible materials, gasoline, and other flammable vapors and liquids.

**The following maintenance items are required for the proper operation of your water heater.**

The appliance must be inspected annually by a licensed professional. Repairs and maintenance should be performed by a licensed professional. The licensed professional must verify proper operation after servicing.

#### **Cleaning**

It is imperative that control compartments, burners, and circulating air passageways of the appliance be kept clean.

Clean as follows:

1. Turn off and disconnect electrical power. Allow to cool.
2. Close the water shut off valves. Remove and clean the water inlet filter.
3. Remove the front panel by removing 4 screws.
4. Use pressurized air to remove dust from the main burner, heat exchanger, and fan blades. Do not use a wet cloth or spray cleaners on the burner. Do not use volatile substances such as benzene and thinners. They may ignite or fade the paint.
5. Use soft dry cloth to wipe cabinet.

#### **Air Inlet / Exhaust Outlet**

The air inlet and exhaust outlet should be inspected at least annually for blockages or damage. If it is blocked contact a licensed professional.

#### **Motors**

Motors are permanently lubricated and do not need periodic lubrication. However you must keep fan and

motor free of dust and dirt by cleaning annually.

#### **Temperature Controller**

Use a soft damp cloth to clean the temperature controller. Do not use solvents.

#### **Lime / Scale Build-up and Water Quality**

If you receive diagnostic code "LC#" (LC1, LC2,...), refer to the procedure, *Flushing the Heat Exchanger*. Refer to the section on *Water Quality* to see if your water needs to be treated or conditioned. (When checking maintenance code history, "00" is substituted for "LC#".)

**The water must be potable, free of corrosive chemicals, sand, dirt, or other contaminants. It is up to the installer to ensure the water does not contain corrosive chemicals, or elements that can affect or damage the heat exchanger. Water that contains chemicals exceeding the levels below affect and damage the heat exchanger. Replacement of the heat exchanger due to water quality damage is not covered by the warranty.**

#### **Snow Accumulation**

Keep the area around flue terminal free of snow and ice. The appliance will not function properly if the intake air or exhaust is impeded (blocked or partially blocked) by obstructions.

#### **Coastal Installations**

Installations located in or near coastal areas may require additional maintenance due to corrosive airborne ocean salt.

### Clean the water filter

Clean the inlet water filter by closing the cold and hot water inlet isolation (shut-off) valves. Put a bucket under the filter at the bottom of the water heater to catch any water that is contained inside the unit. Unscrew the water filter. Rinse the filter to remove any debris. Install the filter and open the isolation valves.

### ⚠️ WARNING / AVERTISSEMENT

Testing the pressure relief valve should only be performed by a licensed professional. Water discharged from the pressure relief valve could cause severe burns instantly or death from scalds.

#### Pressure Relief Valve:

Operate the valve manually once a year. In doing so, it will be necessary to take precautions with regard to the discharge of potentially scalding hot water under pressure. Ensure discharge has a place to flow. Contact with your body or other property may cause damage or harm.

#### Visual Inspection of Flame

Verify proper operation after servicing. The burner must flame evenly over the entire surface when operating correctly. The flame must burn with a clear, blue, stable flame. See the parts breakdown of the burner for the location of the view ports. The flame pattern should be as shown in the figures below.

#### SATISFACTORY

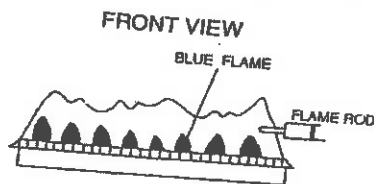

#### UNSATISFACTORY

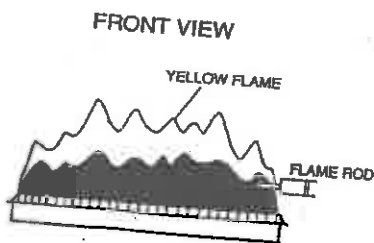

#### Freeze Protection

Make sure that in case of freezing weather that the water heater and its water lines are adequately

protected to prevent freezing. Damage due to freezing is not covered by the warranty. Refer to section on Freeze Protection.

- Drain down solenoid valves be purchased and installed that will automatically drain the unit if power is lost. These are available in a kit, 104000059. (The condensate trap is not affected by the auto drain down solenoid valves and will have to be manually drained.)

#### Winterizing

These recommendations are intended to suggest practices which are effective for winterizing the water heater. They should be used as a guide only. No liability is assumed for any issues resulting from the use of this information.

#### GAS

Shut off the gas to the water heater. It is generally preferable to shut off the gas service to the entire location if gas is not going to be used.

#### WATER

Shut off the cold water supply to the water heater. It is generally preferable to shut off the water to the entire location if water is not going to be used.

Drain the water heater by opening the drain valves on the cold water line and hot water line.

Open several hot water taps and remove the filter assembly at the water inlet in order to allow room for expansion in case there is water in the lines that freeze.

#### ELECTRIC

Disconnect the power supply by either unplugging the electrical cord or by turning off the circuit breaker to the water heater to prevent potential damage from irregular power surges or interruptions.

#### AIR INLET AND EXHAUST

Place a cover over the front panel (air inlet and exhaust). The cover should be easy to apply and remove. This will prevent debris, leaves, and small animals from entering the water heater which could cause air flow issues upon return to service.

## Flushing the heat exchanger

An LC or "00" diagnostic code indicates the unit is beginning to lime up and must be flushed. Failure to flush the appliance will cause damage to the heat exchanger. Damage caused by lime build-up is not covered by the unit's warranty.

1. Disconnect electrical power to the water heater.
2. Close the shutoff valves on both the hot water and cold water lines (V3 and V4).
3. Connect pump outlet hose (H1) to the cold water line at service valve (V2).
4. Connect drain hose (H3) to service valve (V1).
5. Pour 4 gallons of undiluted virgin, food grade, white vinegar into pail.
6. Place the drain hose (H3) and the hose (H2) to the pump inlet into the cleaning solution.
7. Open both service valves (V1 and V2) on the hot water and cold water lines.
8. Operate the pump and allow the vinegar to circulate through the water heater for at least 1-hour at a rate of 4 gallons per minute (15.1 liters per minute).
9. Turn off the pump.
10. Rinse the vinegar from the water heater as follows:
  - a. Remove the free end of the drain hose (H3) from the pail. Place in sink or outside to drain.
  - b. Close service valve, (V2), and open shutoff valve, (V4). Do not open shutoff valve, (V3).
  - c. Allow water to flow through the water heater for 5 minutes.
  - d. Close shutoff valve (V4). When unit has finished draining remove the in-line filter at the cold water inlet and clean out any residue. Place filter back into unit and open valve (V4).
  - e. Close service valve, (V1), and open shutoff valve, (V3).
11. Disconnect all hoses.
12. Restore electrical power to the water heater.

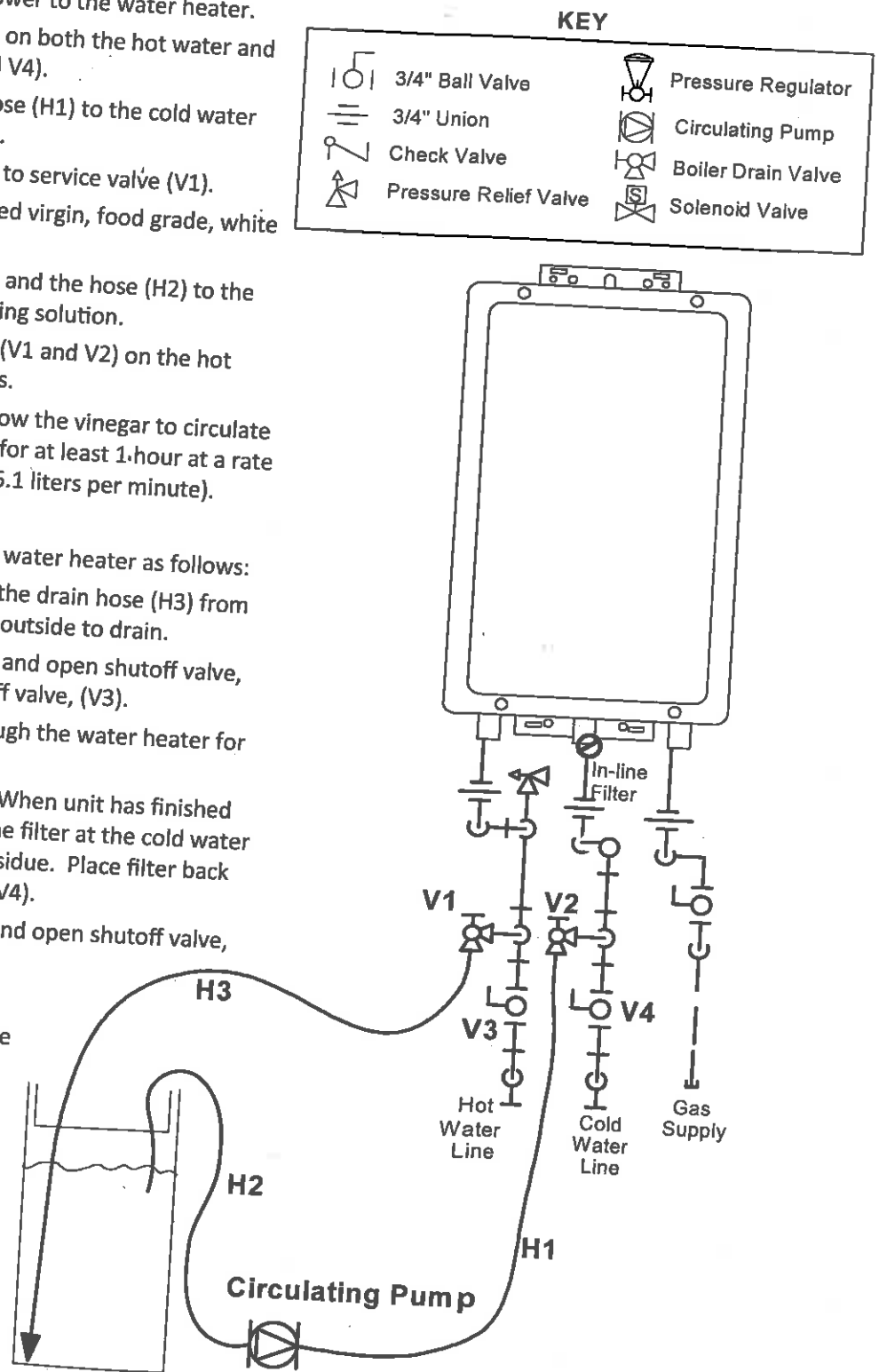

## Manual Draining of the Water Heater

### **⚠ WARNING / AVERTISSEMENT**

To avoid burns, wait until the equipment cools down before draining the water. The water in the appliance will remain hot after it is turned off.

If the water heater is not going to be used during a period of possible freezing weather, it is recommended that the water inside the water heater be drained.

#### To manually drain the water:

1. Shut off cold water supply and gas supply.
2. Turn off the temperature controller.
3. Disconnect the power to the water heater.
4. Place a container to catch the water. Remove the drain caps on both isolation valves and open both valves above the caps (blue and red valve handles). -OR- remove hot water drain plug.
5. Remove water filter to drain the cold water.

#### To resume normal operation:

1. Confirm that the gas supply is turned off, and that all taps are closed.
2. Screw in the water filter in the cold water inlet.
3. Replace the drain caps and close both isolation valves. -OR- install hot water drain plug.
4. Open the cold water supply.
5. Open a tap and confirm that water flows, and then close.
6. Turn on the power.
7. After confirming that the temperature controller is off, turn on the gas supply.
8. Turn on the temperature controller.

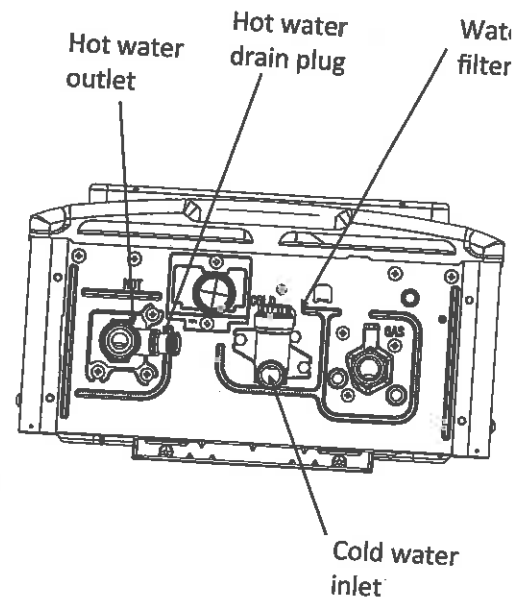

\* Use a wrench or other tool to unscrew the hot water drain plug.

#### **Running a low volume of water through the water heater to prevent freezing**

If the temperature exceeds the ability of the water heater to freeze protect itself, or if power is lost, the following steps may prevent the water heater and external piping from freezing. (Units connected with J-LINK (2 unit link) should be drained to prevent freezing if not in use.)

1. Turn the water heater off.
2. Close the gas supply valve.
3. Turn on a hot water tap to flow water about 0.1 gal/min or where the stream is about 0.2 inches thick.

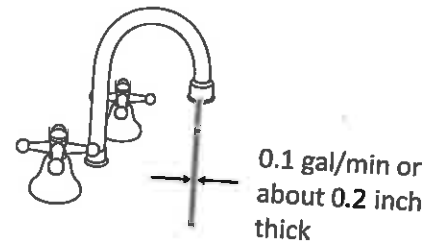

#### **When the water heater or external piping has frozen**

1. Do not operate the water heater if it or the external piping is frozen.
2. Close the gas and water valves and turn off the power.
3. Wait until the water thaws. Check by opening the water supply valve.
4. Check the water heater and the piping for leaks.



# Consumer Warranty

## Limited Warranty

### What is covered?

This Limited Warranty covers any defects in materials or workmanship when the product is installed and operated according to Rinnai written installation instructions, subject to the terms within this Limited Warranty document. This Limited Warranty applies only to products that are installed correctly. Improper installation may void this Limited Warranty. In order for this warranty to apply, it is required that you use a licensed professional who has attended a Rinnai installation training class before installing this water heater. This Limited Warranty extends to the original purchaser and subsequent owners, but only while the product remains at the site of the original installation. This Limited Warranty only extends through the first installation of the product and terminates if the product is moved or reinstalled at a new location.

### How long does coverage last?

Item	Period of Coverage (from date of purchase)		
	Residential Applications	If installed with a tankless isolation valve kit for residential applications	If used for both residential water heating and space heating purposes
Heat Exchanger	10 years [1]	12 years [1]	10 years [2]
All Other Parts and Components	5 years [1]	5 years [1]	5 years [2]
Reasonable Labor	1 year	1 year	1 year

[1] The warranty period is reduced to 3 years from date of purchase when the water heater is used as a circulating water heater within a hot water circulation loop, where the water heater is in series with a circulation system and all circulating water flows through the water heater, and where an on-demand recirculation system is not incorporated.

On-demand recirculation is defined as a hot water recirculating loop or system that utilizes existing hot and cold lines or a dedicated return line, and only activates when hot water is used. It can be activated by a push button, motion sensor, or voice activation but not by a temperature sensor. A timer added to a standard recirculating pump is not considered as on-demand.

[2] The air handler pump must be sized for the flow rate of the heat load, pressure losses through air handler coil, pressure losses through Rinnai tankless water heater, piping and components connecting the air handler and tankless unit. Refer to the tankless water heater pressure loss curve and consult with the air handler/component manufacture for pressure loss information.

### What will Rinnai do?

Rinnai will repair or replace the covered product or any part or component that is defective in materials or workmanship as set forth. Rinnai will pay reasonable labor charges associated with the repair or replacement of any such part or component. All repair parts must be genuine Rinnai parts. All repairs or replacements must be performed by an individual or servicing company that is properly trained, state qualified or licensed to do the type of repair.

Replacement of the product may be authorized by Rinnai only. Rinnai does not authorize any person or company to assume for it any obligation or liability in connection with the replacement of the product. If Rinnai determines that repair of a product is not possible, Rinnai will replace the product with a comparable product at Rinnai's discretion. The warranty claim for product parts and labor may be denied if a component or product returned to Rinnai is found to be free of defects in material or workmanship; damaged by improper installation, use or operation; or damaged during return shipping.

### How do I get service?

You must contact a state qualified/licensed professional for the repair of a product under this Warranty. For the name of a licensed professional please contact your place of purchase, visit the Rinnai website ([www.rinnai.us](http://www.rinnai.us)), call Rinnai at 1-800-621-9419 or write to Rinnai at 103 International Drive, Peachtree City, Georgia 30269.

proof of purchase is required to obtain warranty service. You may register this product within 30 days of purchase you may show proof of purchase with a dated sales receipt. To register your tankless water heater, please visit [www.rinnai.us](http://www.rinnai.us). For those without internet access, please call 1-800-621-9419 . Receipt of Registration by Rinnai will constitute proof-of-purchase for this product. However, Registration is not necessary in order to validate this Warranty.

#### What is not covered?

- accident, abuse, or misuse
- alteration of the product or any component part
- misapplication of this product
- improper installation (such as but not limited to)
  - ◊ product being installed in a corrosive environment
  - ◊ condensate damage
  - ◊ improper venting
  - ◊ incorrect gas type
  - ◊ incorrect gas or water pressure
  - ◊ absence of a drain pan under the appliance
- water quality
- Improper maintenance (such as but not limited to scale build-up, freeze damage, or vent blockage)
- incorrect sizing
- any other cause not due to defects in materials or workmanship
- problems or damage due to fires, flooding, electrical surges, freezing or any acts of God.
- force majeure

This Warranty does not cover any failures or operating difficulties due to the following:

There is no warranty coverage on product installed in a closed loop application, commonly associated with space heating only applications.

The integrated controller on indoor models has a 1 year warranty on parts.

There is no warranty coverage for commercial applications.

This Limited Warranty does not apply to any product whose serial number or manufacture date has been defaced.

This Limited Warranty does not cover any product used in an application that uses chemically treated water such as a pool or spa heater. This appliance is suitable for filling large or whirlpool bath tubs with potable water. Refer to the Water Quality Section in the Operation and Installation Manual.

#### Limitation on warranties

No one is authorized to make any other warranties on behalf of Rinnai America Corporation. Except as expressly provided herein, there are no other warranties, expressed or implied, including, but not limited to warranties of merchantability or fitness for a particular purpose, which extend beyond the description of the warranty herein and further Rinnai shall not be liable for indirect, incidental, special, consequential or other similar damages that may arise, including lost profits, damage to person or property, loss of use, inconvenience, or liability arising from improper installation, service or use. Some states do not allow the exclusion or limitation of incidental or consequential damages, so the above limitation may not apply to you.

Any implied warranties of merchantability and fitness arising under state law are limited in duration to the period of coverage provided by this Limited Warranty, unless the period provided by state law is less. Some states do not allow limitations on how long an implied Limited Warranty lasts, so the above limitation may not apply to you.

This Limited Warranty gives you specific legal rights, and you may also have other rights which vary from state to state.

[www.rinnai.us/warranty](http://www.rinnai.us/warranty)